

PrintPAD CN70

User Guide ■■■

right by our customers. ■■■



datamax•o'neil

- PrintPAD CN70 Printer Views**..... 1
 - Open View..... 1
 - Closed View..... 1
- Using Batteries: General Guidelines**..... 1
 - Installing and/or Replacing Batteries 2
- Charging the Batteries and Handheld Computer** 2
- Determining Battery Condition** 3
- Installing the Driver** 3
- Using a Handheld Computer (HHC)** 3
 - Compatible Handheld Computers 3
- Loading Paper** 4
- Printing a Self-Test**..... 5
- Configuring the Printer** 5
- Using the Printer Data Cables**..... 5
- Using Bluetooth** 6
 - Bluetooth Parameters..... 6
- PrintPAD CN70 Indicators**..... 6
 - Power LEDs..... 6
 - Audio Indicators..... 7
 - Radio LED 7
 - Power LED..... 7
 - CardReader Audio Indicators..... 7
- Using DEX/UCS Capabilities**..... 7
- Using a CardReader** 8
 - General Guidelines 8
 - CardReader Indicators..... 8
- Using External Charging**..... 8
 - Overview..... 8
- Agency Approvals** 10
- Copyright and Supplies** 11

PrintPAD CN70 Printer Views

Open View

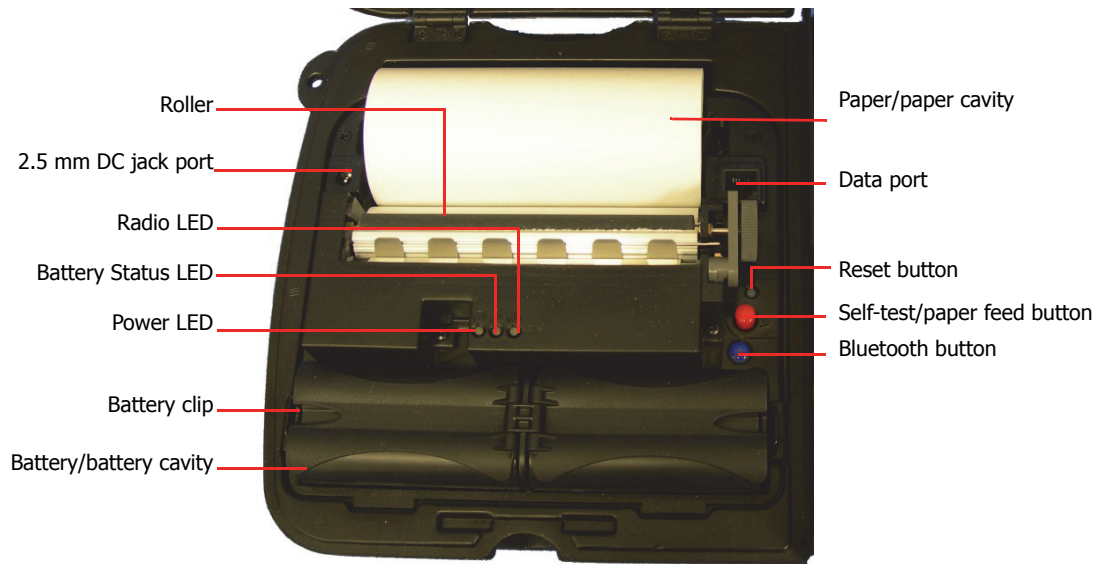

Closed View

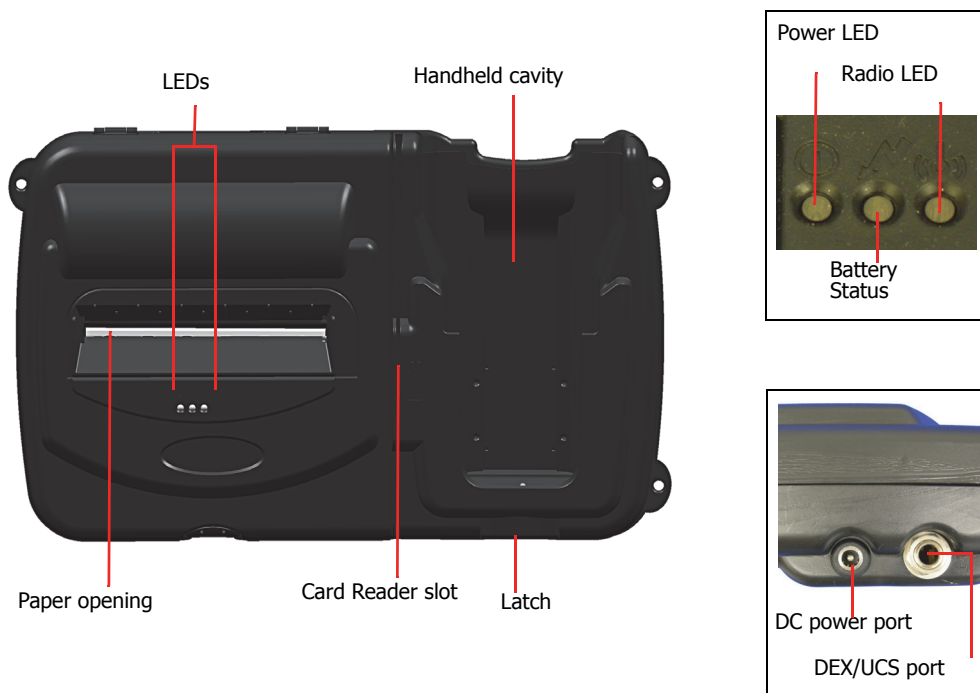

Using Batteries: General Guidelines

- The printer ships with two batteries installed, but they are not operational. Before operating the printer, remove the two red, battery isolator labels either by gently pulling the labels out, or by lifting the batteries up.
- If you are storing your printer for a long period of time or shipping it, reinstall the battery isolator labels.
- Both batteries must be installed for your printer to operate properly.

Installing and/or Replacing Batteries

1. Open the printer by unsnapping the latch on the front of the case (Figure 1).
2. Lift the battery cover up by pushing the retainer clip inward with your finger (Figure 2).



Figure 1



Figure 2

3. Lift up the outside end of the battery to remove it.
4. Insert the new batteries. Verify the battery contacts are facing down and are facing the outside edge of the printer (Figure 3).



Figure 3

Contacts



5. Close the battery cover by snapping it into place.

Charging the Batteries and Handheld Computer

If the battery is low when the printer "wakes up," the printer sounds three short beeps.

1. Remove the red battery isolator labels, if necessary.
2. Plug the power supply connector into the printer's external DC port. The DC port is located on the side of the printer's case (Figure 4).

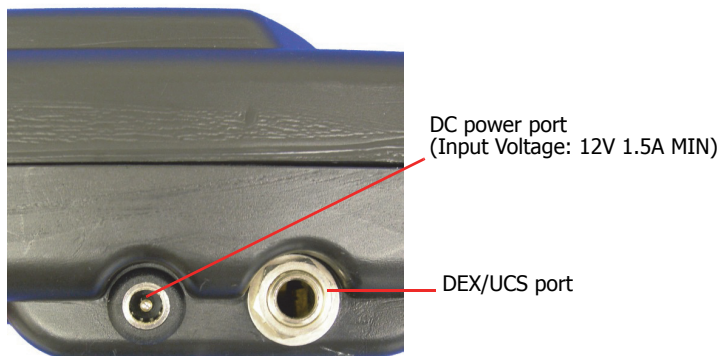

Figure 4

3. Plug the adapter in an appropriate power source.

The Charge LED flashes red when charging and flashes green when fully charged. The Charge LED is visible when the printer's lid is open or closed. A complete charge takes approximately 7-9 hours. For more information on the Charge LEDs, see *PrintPAD CN70 LEDs and Indicators on page 6*.

Note: To obtain full battery capacity, a new battery must cycle through two to three charges. To restart a charge, unplug the power cord. Wait 30 seconds, then replug the power cord.

The CN70 Handheld Computer will charge while power is plugged into the DC power port.

Caution: Do not plug DC power into the internal and external power ports at the same time.

Do not plug the DC power supply into the printer if the printer is being charged by means of external charge contacts.

Determining Battery Condition

You can determine the relative battery condition by printing a self-test. For more information, see *Printing a Self-Test on page 5*. On the printout, "Battery Volt" varies between 6.8 and 8.4 volts.

Caution: There is a risk of explosion if the battery is replaced by an incorrect type. Dispose of used batteries according to the instructions.

The operating temperature of this portable printer is 50° C. However, the operating temperature when used with Datamax-O'Neil power supply for charging the portable printer is limited to 40° C. Charge the printer in a suitable location that meets this temperature requirement.

(For US/Canada) Use only the Datamax-O'Neil part number 220240-100 power supply with this product.

Installing the Driver

Note: Before using the CN70, it is necessary that the appropriate USB driver is installed. Refer to the USB Installation Guide for more information.

1. Go to www.datamax-oneil.com and click *Support* to obtain the appropriate driver for the PrintPAD CN70.
2. Install the driver onto the handheld computer.

Using a Handheld Computer (HHC)

1. Insert the handheld into the cavity by sliding it in from the top.
2. Press down until the handheld is fully latched and seated.

Compatible Handheld Computers

Note: The PrintPad CN70 series is intended for use with the UL Listed Accessory Handheld Computer Intermec Technologies Corp 1000CP01 series or the UL Listed Accessory Handheld Computer Intermec Technologies Corp 1000CP02 series.

Loading Paper

1. Press a new roll of paper into the paper cavity. The end of the roll should exit from the bottom of the paper cavity and face the printer's roller (Figure 8). When properly installed, the roll of paper "latches" into place.

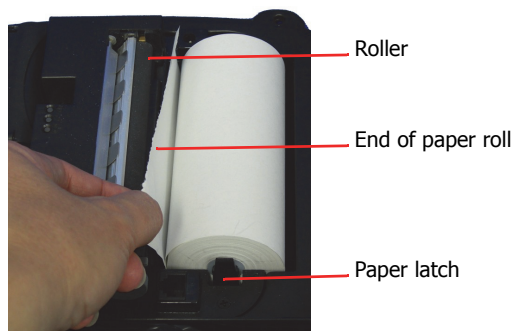

Figure 8

2. Raise the printhead release lever until it is fully open. The lever clicks midway at the partially open position; however, do not stop here, continue to raise the lever until it is fully open (Figure 9).
3. Wake up the printer by momentarily pressing the red self-test button (Figure 10).

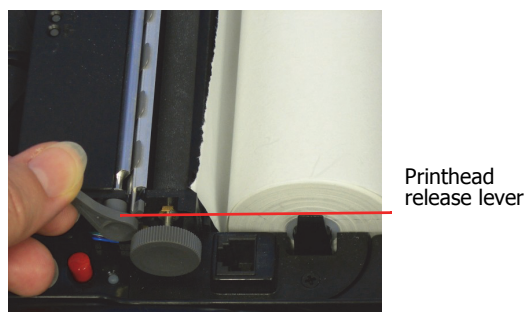

Figure 9

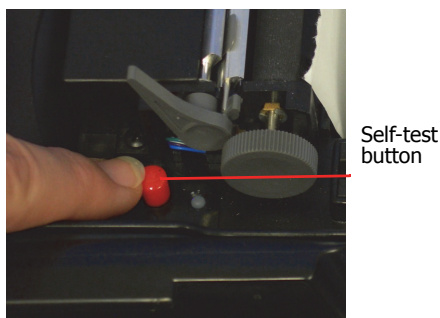

Figure 10

4. Feed the end of the paper and center it under the roller until the paper exits from the top of the printhead (Figure 11). The printer has an auto advance feature that will aid moving the paper through the printer. Verify the paper exits straight.
5. Lower the printhead release lever (Figure 12).



Figure 11

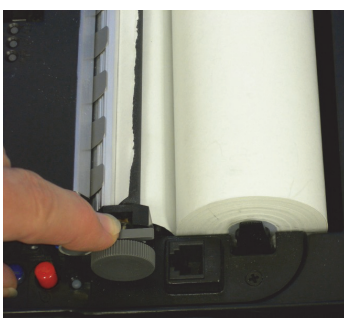

Figure 12

6. Remove any excess paper by grasping the top corner of the paper and pulling it up and away.
7. Close and latch the printer's cover.

Printing a Self-Test

1. Open the printer's cover.
2. Press and hold the red self-test button for 4-5 seconds, until the printer starts to print (Figure 13).

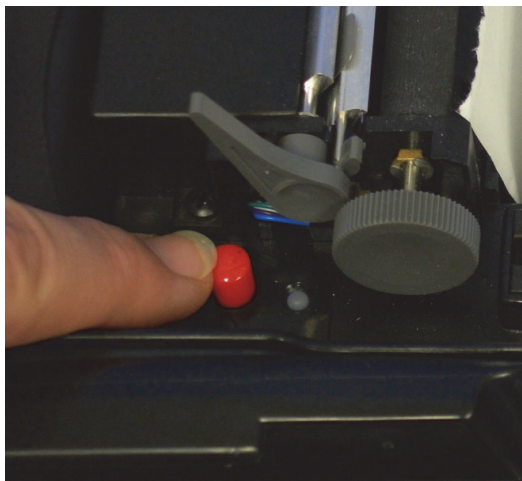

Figure 13

3. After printing starts, release the red self-test button.

Configuring the Printer

The printer has many configurable settings. To configure or upgrade firmware, download the Windows configuration program at www.datamax-oneil.com.

Using the Printer Data Cables

1. Select the appropriate cable for use with the host and/or device you are using.
2. Insert the plug into the printer's data port (Figure 14).



Figure 14

Note: Do not close the lid or damage will occur to the cable. The data cable is intended only for reflashing the printer.

Using Bluetooth

Note: The following information applies to printers with Bluetooth capabilities.

Radio printers are configured with default factory settings. To determine your printer's radio configuration, print a self-test. (For more information, see *Printing a Self-Test on page 5*.) If you have multiple printers, configure them specifically for use in your environment.

For proper system operation, set the following parameters on your printer and host computer:

Bluetooth Parameters

- Device Name
- Authentication
- Bondable
- Discoverable
- Connectable
- Encryption

Contact your network administrator to verify the proper radio settings for your environment.

PrintPAD CN70 LEDs and Indicators

Power LEDs

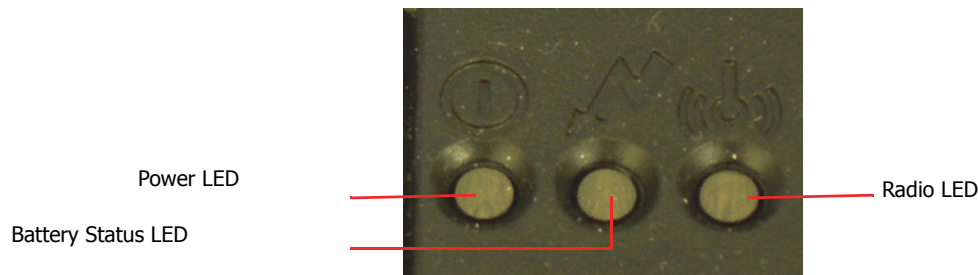

Battery Status LED	Description	Action
Red (solid): The battery has less than 5% power.	<ul style="list-style-type: none"> • If A/C power is not plugged in, the printer will soon turn off. • If A/C power is plugged in, the LED flashes and charging is in progress. 	<ul style="list-style-type: none"> • Charge the battery. • None. Wait for the charge LED to turn green.
Orange (solid): The battery has less than 25% power.	<ul style="list-style-type: none"> • If A/C power is not plugged in, indicates the battery charge is low. • If A/C power is plugged in, the LED flashes and charging is in progress. 	<ul style="list-style-type: none"> • Charge the battery. • None. Wait for the charge LED to turn green.
Green (solid): The battery is near, or at, full capacity.	<ul style="list-style-type: none"> • If A/C power is not plugged in, the battery is well charged. • If A/C power is plugged in, the LED is solid and charging is complete. 	<ul style="list-style-type: none"> None. None.
Red to orange flash - fast	Battery voltage is too high.	Replace battery.
Orange flash - slow	Charge has timed out.	Restart battery charge (battery may be bad).
Orange flash - fast	Internal code error.	Remove the battery, then re-connect A/C power.
Orange, red, or green flash - fast	When the AC adapter is plugged into the printer's power port, the battery status LED flashes orange, red, or green (depending on the battery status LED color that is initially displayed) to indicate the AC adapter is plugged in.	None.

Audio Indicators

Beep(s)	Description	Action
1	Printer wakes up.	None.
2	Out of paper.	Install paper.
3	Low battery.	Charge battery.
1 short	RF power is on (when blue, RF power button is pressed and power was turned off).	None.
2 short	RF power is off (when blue, RF power button is pressed and power was turned on).	None.
1 long	Boot code is starting or restarting (when downloading new firmware).	Redownload firmware.
8 short	CRC error in firmware.	Redownload firmware.

Radio LED

Radio LED	
Blue flash - slow	RF power is on and printer is asleep.
Blue flash - fast	RF power is on and printer is awake.
Off	RF power is off.

Power LED

Power LED	Description
Off	Printer is asleep.
Red flash	Paper out.
Green	Unit is awake.

CardReader Audio Indicators

Magnetic

Beep(s)	Description	Action
1 long	Bad read.	None.
2 short	Good read.	None.

Using DEX/UCS Capabilities

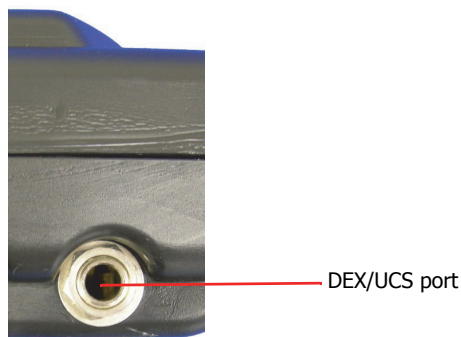

Figure 15

The direct exchange (DEX)/UCS port can only be used with the Datamax-O'Neil approved DEX cable (P/N 210237-xxx). When the DEX cable is plugged into the data port, the printer automatically turns off to allow data transfer between the handheld and the DEX port. Remove the DEX cable to resume connection to the printer.

Note: Do not unplug the cable in the middle of a data transfer session.
Your application needs to be programmed to communicate in the DEX/UCS language.

Using a CardReader

Note: The following information applies to printers with the CardReader option.



Figure 16

General Guidelines

- To wake up the CardReader, insert a card into the CardReader slot. One short beep indicates the CardReader/printer is awake.
- If you are using a Magnetic CardReader, insert a card with the stripe facing away from the printer. The card can be swiped in either direction.
- For information on CardReader LED indicators and audio indicators, see *CardReader Indicators on page 8*.

CardReader Indicators

Audio Indicators

Beep	Description	Action
1 long	Bad read.	Swipt card again.
2 short	Good read.	None.

Using External Charging

Note: The following information applies to printers installed with external charge capabilities.



(2) Charging contact points

Figure 17

Overview

External charge-capable printers have two charging contact points located on the back of the printer's case (Figure 17).

External charge-capable printers can be used with various Datamax-O'Neil accessories, such as the truck mount bracket. When an external charge-capable printer is mounted to one of these accessories, the printer's batteries are automatically charged. For more information, see the instruction sheet(s) included with the accessories.

Warning: Use of any product not approved by Datamax-O'Neil for use with their printers could cause damage to the batteries and/or printer and will void the warranty.

DO NOT plug the DC jack power supply into the printer if the printer is being used in conjunction with an external charging bracket, mount, or stand.

Failure to observe the instructions and/or warnings specified in the documentation may result in damage to your printer. Datamax-O'Neil does not accept liability for resulting damages or injuries.

Agency Approvals

FCC Notice

This equipment has been tested and found to comply with the limits for a Class B digital device, pursuant to Part 15 of the FCC Rules. These limits are designed to provide reasonable protection against harmful interference in a residential installation.

This equipment generates, uses and can radiate radio frequency energy and, if not installed and used in accordance with the instructions, it may cause harmful interference to radio communications. However there is no guarantee that interference will not occur in a particular installation. If this equipment does cause harmful interference to radio or television reception, which can be determined by turning the equipment off and on, the user is encouraged to try to correct the interference by one or more of the following measures:

- Reorient or relocate the receiving antenna.
- Increase the separation between the equipment and receiver.
- Connect the equipment to an outlet on a circuit different from that to which the receiver is connected.
- Consult the dealer or an experienced radio/TV technician for help.



Applicable Directives

- 2004/108/EC, 73/23/EEC, 2011/65/EU

Applicable Standards

- EN55022 (2006)
- EN55024 (1998), A1 (2001), A2 (2003)
- IEC60950-1 (2005)



Copyright

This manual and any examples contained herein are provided "as is" and are subject to change without notice. Datamax-O'Neil makes no warranty of any kind with regard to this manual, including, but not limited to, the implied warranties of merchantability and fitness for a particular purpose. Datamax-O'Neil shall not be liable for any errors or for incidental or consequential damages in connection with the furnishing, performance, or use of this manual or the examples herein. This guide is copyrighted. All rights are reserved. This guide may not, in whole or in part, be reproduced, translated, stored in a retrieval system or transmitted in any form or by any means, electronic, mechanical, photographic, or otherwise, without the prior written consent of Datamax-O'Neil.

Trademarks

All product and company names are trademarks, service marks or registered trademarks of their respective owners.

Media Supplies

Datamax-O'Neil offers seven certified grades of paper for use in the PrintPAD series of printers. Our certified supplies are guaranteed compatible — this important qualification means that rigorous performance and image life testing have been performed. Quality supplies are key to obtaining optimal image quality and print performance. Quality supplies are also the key to extending the life of the printer. Datamax-O'Neil strongly recommends using Datamax-O'Neil Certified Supplies only.

For more information, contact Datamax-O'Neil at 407-523-5650.

Maintenance Supplies

We recommend that you follow a regular maintenance schedule using our cleaning card (or cleaning kit when using linerless labels). Datamax-O'Neil cleaning cards are designed to effectively remove dirt and other contaminants from the thermal printhead, rollers, and paper path...resulting in a clean, crisp image output — every time. Our cleaning kits remove any adhesive residue in addition to dirt and other contaminants.

For more information, contact Datamax-O'Neil at 407-523-5650.

For more information

For information about using the printer, contact Datamax-O'Neil at 407-523-5650, or visit www.datamax-oneil.com.

